

Lending to the Unbanked: Relational Contracting with Loan Sharks*

Kevin Lang[†], Kaiwen Leong[‡], Huailu Li[§] and Haibo Xu[¶]

September 25, 2019

Abstract

We study roughly 11,000 loans from unlicensed moneylenders to over 1,000 borrowers in Singapore and provide basic information about this understudied market. Borrowers frequently expect to repay late. While lenders do rely on additional punishments to enforce loans, the primary cost of not repaying on time is compounding of a very high interest rate. We develop a very simple model of the relational contract between loan sharks and borrowers and use it to predict the effect of a crackdown on illegal moneylending. Consistent with our model, the crackdown raised the interest rate and lowered the size of loans.

JEL code: K42, L14

Keywords: Illegal Lending, Enforcement, Relational contract

*The data were collected by Leong who first obtained approval to use this dataset to study the unlicensed moneylending market by writing to the appropriate Singaporean authorities. He then submitted an application to the Nanyang Technological University (NTU) IRB to obtain ethics approval. Waiver of the signature acknowledging informed consent was requested because almost all borrowers Leong spoke to prior to conducting the study explained that borrowers would typically not sign any documents because they fear being identified. Thus, they were not willing to have any paper trace of their name. Instead, verbal consent was obtained before the commencement of the interviews. The data collection was self-funded. Leong acknowledges Singapore's Ministry of Education for funding part of this research. We thank Costas Cavounidis and Bart Lipman for their helpful comments. The usual caveat applies.

[†]Department of Economics, Boston University. Email: lang@bu.edu

[‡]Division of Economics, Nanyang Technological University. Email: kleong@ntu.edu.sg

[§]Department of Economics, Fudan University. Email: huailuli@fudan.edu.cn

[¶]Department of Economics, Fudan University. Email: haiboxu@fudan.edu.cn

1 Introduction

Most of what economists know about illegal moneylenders or loan sharks comes from Hollywood, which typically portrays them as violent and unscrupulous exploiters of naive, desperate, and powerless clients from whom they extract all possible surplus. Our study of roughly 1,100 individuals who took out approximately 11,000 loans from loan sharks shows that this portrayal is very imperfect. While it is true that borrowers pay extraordinarily high interest rates and many suffer from impulse control problems, chemical addictions and/or gambling addiction, their interactions with loan sharks are governed by a relational contract that does not leave them on their participation constraint. Borrowers entering into contracts know the rules and have often previously transacted with the same lender. If they repay on time, they are rarely harassed. Nevertheless, most borrowers expect not to repay on time, and so, with compounding interest, their debt grows rapidly. Eventually, however, almost all manage to repay the loan. In particular, as we show formally, if borrowers were on their participation constraint, a police crackdown on illegal moneylenders would have no effect on the interest rate lenders charge. We show empirically that when Singapore started enforcing its laws against loan sharks more rigorously, the interest rate in this market increased dramatically, demonstrating that borrowers have some bargaining power.

Despite the vast size of underground lending markets, little is known about their inner workings and the effects of enforcement activities designed to curb them.¹ According to Chaia *et al.* (2010), there are more than two billion adults worldwide who are defined as “unbanked”. Many of these rely on unregulated and, sometimes, illegal lenders. Among emerging economies, the size of unlicensed lending is estimated to be \$780 billion in China (or nine percent of GDP at the time), \$471 billion in India and \$172 billion in Thailand (Prabha and Ratnatunga, 2014). The market in developed economies is probably smaller but not negligible. Meikle (2014) conservatively estimates around US\$1 billion is paid to unlicensed moneylenders a year in the UK.

This market is interesting not just because of its magnitude, but also because it represents an extreme example of relational contracting. Lenders are unable to pursue borrowers in court, and borrowers are unlikely, and frequently unable, to seek protection from law enforcement or the courts. Lenders, on the other hand, can and sometimes do have recourse to punishments that go beyond simply refusing to continue the relationship.

¹There is a large body of literature devoted to legal personal loans, the credit card market and the sub-prime markets such as the payday loans market and the authorized moneylending market. The unlicensed moneylending market differs from these legal financing options in many dimensions. For example, there is no underwriting conducted and there is no legal entity to handle any disputes that arise from transactions between the borrowers and lenders.

In this paper, we provide some basic evidence about the characteristics of borrowers from illegal moneylenders (or loan sharks) in Singapore,² the nature of the contracts between the lenders and borrowers, and the methods used by lenders to enforce repayment. Drawing on this information, we develop a simple model of the relationship, which we use to predict the effect of enforcement crackdowns on the relational contracts between borrowers and unlicensed moneylenders. Finally, we return to the data and examine this issue empirically.

The contracted interest rate in our sample is very high and far in excess of the cap set by Singapore's usury law. Both borrowers and lenders describe the standard contract in the pre-crackdown period as twenty percent for six weeks. However, our understanding is that the agreement often requires six payments, each equal to twenty percent of the nominal loan amount, the first of which is sometimes deducted from the initial loan amount. In such cases, the loan effectively has a tenure of five weeks at an interest rate of almost eight percent per week. Even if the six payments are spread out over the following six weeks with no initial payment, the implied interest rate would be about 5.5 percent per week.

Failure to repay the loan in full and on time is the norm rather than the exception, and lenders continue to charge high interest on late payments. Nevertheless, almost all loans are eventually repaid in full, although sometimes the borrower pays by working for the lender. Moreover, borrowers should not be surprised by their failure to repay on time. About 70 percent report that they fail to repay loan sharks on time regularly or frequently. Many report having gambling, drug and/or drinking problems. Strikingly, borrowers report relatively few incidents of significant harassment when they repay on time, suggesting that lenders, for the most part, abide by the agreement.

Our model predicts that increased enforcement increases the contracted interest rate unless borrowers have no bargaining power. Informally, this should, in turn, make it more difficult for borrowers to repay their loans on time. Our formal model implies no effect on harassment activities. Consistent with the model, we find that cracking down on illegal moneylending raised the interest rate and lowered the size of loans. The increase in the nominal interest rate, from 20 to 35 percent for six weeks, seems large and suggests to us both that police activity was successful in making illegal moneylending more difficult and that the bargaining power of borrowers is nontrivial. Somewhat inconsistent with the model, there was an increase in the mildest forms of loan enforcement such as possibly menacing reminders, phone calls and letters.

Given the lack of data on illegal moneylending elsewhere, it is difficult to assess the external validity of our setting, but as we have already noted, the sector is similarly large

²According to Kok (2001), unofficial figures by the Singapore Association of Underground Bankers show that unlicensed moneylending amounts to some 9% of the total GDP.

in other Asian countries. In addition, there are reasons to expect that Singapore is not unusual. Singapore has a well-developed and modern banking system. It also has licensed moneylenders. Similar to many countries, Singapore has usury laws that cap the interest rate for legal loans disbursed by licensed moneylenders at 4% per month. As is likely to be true elsewhere, the illegal market attracts borrowers who were rejected by formal financial institutions, with the majority not meeting the minimum income requirements for legal loans, or who have too many unpaid outstanding loans to qualify for additional borrowing.

As Ho (2016) has documented, lenders offer quick and convenient short-term loans disbursed in small amounts such as S\$500, repayable over four to six weeks on average. Carina (2018) claims that, in contrast with the formal sector, lenders usually do not require collateral or financial statements that prove credit worthiness, and can provide money within 30 minutes. This is consistent with testimonies from our informants.

Some aspects of the market are almost certainly unique to the Asian setting and we expect that such aspects are unlikely to extend to the markets in Europe and North America. For example, in the Asian setting, there is the importance of ‘face.’³ As a consequence, there are no reports of physical violence in our data but many reports of actions designed to embarrass the borrower. Consistent with this approach, moneylenders providing loans to female university students in China have been reported to require the female students to pose naked for low-quality photos. While we expect that enforcement methods are different in the west, we also expect that they will share the characteristic that they hurt borrowers without supplying the lenders with any value and may even be costly to the lenders.⁴ It is beyond the scope of this paper to assess how important the potential for actions that serve solely to hurt the other party are for the enforcement of relational contracts more broadly, but we suspect that they are far from unique to illegal moneylending.

2 Data Collection

We began by using individuals with close connections to the world of illegal moneylending to gather basic information on the milieu.⁵ These initial contacts included individuals in voluntary organizations working with borrowers and individuals involved in law enforcement.

³‘Face’ means reputation or honor.

⁴Note that there have been no reports of the Chinese moneylenders using the photos for profit. This is consistent with their low quality. Instead, it appears that the lenders threaten to send these nude photos to relatives.

⁵We use ‘we’ throughout this section, but only one of the authors, Kaiwen Leong, was entirely responsible for data collection. The preparatory work was conducted during Leong’s one-year stint as a social worker after the completion of his PhD and before taking up a position as an assistant professor of economics. The project became a formal data collection effort after he joined Nanyang Technological University.

These individuals put us in touch with borrowers and loansharks.

Using the information from these qualitative interviews and our contacts, we hired 48 enumerators to conduct the formal interviews. The enumerators were local Singaporeans who had previously been involved in the unlicensed moneylending market. The pool of enumerators was chosen to ensure diverse backgrounds, which included ex-offenders, gamblers, small business owners and former unlicensed moneylenders. We trained the enumerators in proper interview procedures and ethics. In particular, they were instructed not to force respondents to answer questions that the respondents were not comfortable discussing.

We rely on a snowball sample. The first members of the sample were individuals known to the enumerators. The enumerators asked respondents to put them in touch with other borrowers. The enumerators would then phone or meet the suggested respondent, often with the person who made the introduction present, and determine whether the proposed respondent was willing to participate in the survey. The enumerators started by explaining to potential respondents that the survey was about the economic behavior of borrowers (not of any individual in particular) and that their individual information would not be disclosed to anyone except the investigators and enumerators. Respondents were also informed of the types of questions they would be asked, the duration of survey and were reassured that they would not be obliged to answer questions with which they did not feel comfortable and could stop the survey at any time.

Our approach is likely to underrepresent one-off individuals looking to borrow very small sums of money. Our qualitative interviews with participants in the market suggest that such borrowers are a “very tiny fraction” of the market, but we nevertheless recognize this as a limitation of our data.

The enumerators reported 1232 contacts to us. These resulted in 1123 completed interviews at a completion rate of 91 percent. This completion rate is implausibly high. We are sure that there are unrecorded cases where a respondent promised to refer a friend but never provided contact information for that friend, either because the respondent never followed up or the friend refused. We suspect that other quick refusals (“My friend isn’t interested.”), were also not recorded. Nevertheless, the high completion rate of follow-up interviews (97 percent) is consistent with the very low refusal rate reported to us by the enumerators.

There are three reasons for the low refusal rate. First, the interviewees valued the payment of S\$20 to S\$40 they received. Second, prior to the commencement of any interview, all respondents were properly notified of the research study’s purpose and the team’s commitment to maintaining the confidentiality of the respondents’ personal information. When we returned to them for the second wave of interviews, respondents knew that nothing they had revealed to us had been shared with anyone without prior and explicit permis-

sion. Thereafter these respondents were open to accommodating further interviews. Third, the interviews were conducted with the recommendation or physical presence of someone whom the respondent trusted. These individuals shared examples of the types of different confidential data that some of the authors had collected about individuals in the sex and drug industries; they explained to the potential respondents that, as promised to previous respondents, no individual's information had been disclosed to anyone not using the data for academic research. This track record was useful in assuring the borrowers that the team would protect the information entrusted to them.

While we believe that respondents generally provided accurate information, to further ensure the veracity of the information, we paid respondents an extra S\$10 if they provided physical evidence such as diaries, repayment schedules and phone messages from lenders to support their answers. Respondents were generally willing to share this information, with over 50 percent providing proof of their claims. Asking for physical evidence also helped minimize inadvertent recall errors.

Each interview lasted between 1.5 and 2 hours and was conducted at a cafe chosen by the respondent. After the completion of the interviews, the enumerators submitted all the answer sheets to Leong.

We collected the data in two waves. The first wave followed qualitative research and was conducted during 2011-2013. This wave focused on collecting information on borrowers' characteristics and their transactions starting in 2009. The second wave, conducted in 2015 and 2016, collected information on additional transactions since 2014. 1090 of the original sample of 1123 were successfully re-interviewed. The remainder consisted of individuals who were in hiding or who were otherwise unreachable, rather than refusals. The results in this paper are limited to the 1090 borrowers who were interviewed in both waves.

In the first wave, we collected information on up to nine loans during the period covered. While our enumerators were able to contact and interview virtually all of the original respondents, they also reported that respondents were less willing to tolerate a lengthy interview. As a consequence, many interviews reported information on only two loans during the relevant period and only one covered more than five loans. There are a number of reasons that the number of loans reported may have fallen. First, the period covered was noticeably shorter. Second, loans were less readily available, a point we will return to later. As a result, there were probably fewer loans to report. However, almost all the surveys reported exactly two loans, suggesting that this was probably due to decisions on the part of enumerators to restrict the collection of data.

We collected data on 11,032 loans or an average of roughly ten loans per borrower. We have one borrower who reported five loans and eight who reported six. The rest of our

sample provided information on seven to eleven with somewhat more than half reporting exactly eleven.

3 Who Borrows?

3.1 Basic demographics

Our sampling framework is designed to be representative of the stock of borrowers when we began our research. Relative to a sample of people who ever borrow, this sample overrepresents frequent borrowers, but it should be representative of the clients seeking loans from illegal money lenders at a point in time although as noted previously, it probably underrepresents very infrequent borrowers even among this group.

Borrowers are overwhelming male and about half of the men report being currently married. The small sample of female borrowers show high rates of divorce (36 percent) and widowhood (5 percent). The age of the borrowers in our sample ranges from 20 to 63 and averages 38. 40 percent have some post-secondary education compared with the Singaporean average of 54 percent for the 20-64 age group in 2010 (Singstat, 2011).

The borrowers' ethnic composition reflects the ethnic distribution in Singapore although Indians are somewhat overrepresented, and individuals from other than the country's three main ethnicities are somewhat underrepresented, probably reflecting differences in income levels among these groups. The majority of borrowers fall in the lower end of the income distribution. The median monthly income of full-time employed residents in Singapore was S\$3,949 in 2015 (Ministry of Manpower, 2016). In our sample, however, about 75% of the borrowers make less than S\$3,000/month compared with only 35 percent of working persons in 2010. Not surprisingly, individuals with very low incomes are also underrepresented among borrowers.

Despite their low incomes, 92% of the borrowers have a full-time job, and, of these, 84% have a least a full year of tenure in their current job, and 63% report never having been fired from a job. The number of borrowers who are unemployed and have no fixed source of income is negligible, consistent with evidence that lenders engage in at least minimal screening before lending to prospective customers.

At the same time, many borrowers exhibit past behaviors that may interfere with their labor market performance and ability to borrow legally. Four out of ten are (14 percent) or used to be (29 percent) gang members and 21 percent have spent time in prison.

3.2 Spending patterns

Given their incomes, it is perhaps not surprising that the borrowers have very low savings rates compared to the norm in Singapore, but the contrast is striking. The gross national savings rate in Singapore averaged 48 percent during the period we study (CEIC, 2019). Consistent with this, according to the 2012/13 household expenditure survey, the average household monthly income was S\$10,503 while the average household expenditure was S\$4,724. In contrast, nearly two-thirds of our sample reported saving less than ten percent of income and only six reported saving more than thirty percent.

Instead, the borrowers tend to be big spenders. Only five report spending less than ten percent of their monthly income on lavish affairs while over half report spending more than forty percent in this way. Similarly, over half report treating friends to meals or entertainment regularly or very frequently.

A large majority say they drink very frequently (39 percent) or regularly (40 percent). Only 70 percent report that they never use drugs while 18 percent report using them regularly or very frequently. Only 10 percent say they never gamble while over one-third gamble very frequently. Among the men, 5 percent pay for sex workers very frequently and less than one-quarter never do so. This proportion rises to only about one-third among the married men.

3.3 Borrowing behavior

Our borrowers are heavily dependent on loans. Only two percent report borrowing from friends, colleagues and relatives no more than once in a typical year. More than one-fourth say that they do so six or more times per year. Only seven percent say they never fail to repay these debts. This number falls to almost zero among the most frequent borrowers. 60 percent of borrowers say that fail to repay regularly or very frequently.

When asked the sources from which they had borrowed most frequently in the last year, 81 percent listed loansharks, 54 percent listed friends and colleagues and the same proportion listed family or relatives while 8 percent mentioned pawn shops. 11 percent said they borrowed from banks and institutions. They had borrowed from legal moneylenders in the past.

Despite heavy reliance on friends and family, our borrowers have often relied on loan-sharks. Only one percent claim to borrow from a loanshark no more than once in an average year. Well over half (57 percent) typically do so four or more times in a year. Only three say they first borrowed from a loanshark in the past year. The median time is three to five years with 45 percent first having done so more than five years ago. As they do with friends and

family, the borrowers exhibit difficulty repaying the loansharks. Only six claim that they never fail to repay on time.

At the time we first interviewed them, only seven percent reported no debt while a further four percent reported less than S\$1000 in debt. The majority owed more than S\$5,000. Half of those with debt owed money that was due within a week. Almost 90 percent had payments due within a month. Given the magnitude of the debt relative to earnings and the short repayment period, it is unsurprising that borrowers have great difficulty meeting their payment obligations.

3.4 Discounting and risk aversion

We asked borrowers three questions in which they were asked to choose between receiving S\$180 today and either S\$200, S\$220, or S\$240 in a month. An individual who will wait a month for the lowest sum has a discount rate of less than 11.1 percent per month while one who rejects the highest sum has a discount rate of more than 33.3 percent per month. Less than five percent of the borrowers would wait to receive the lowest amount and only 21 percent would wait to receive S\$220. Almost 60 percent indicate that their discount rate for a month exceeds 33 percent.⁶

To complement this question, we asked the borrowers how much they would need in a month to be indifferent between waiting and receiving S\$500 immediately. The question was open-ended. One person indicated a preference for constraining himself and would accept S\$400 in a month and two suggested they were indifferent between receiving S\$500 now or a month from now. On average, however, borrowers again express high discount rates, requiring an average of S\$725 in a month in order to forego S\$500 now. That said, the individual results are not consistent across the questions. There is no clear tendency for borrowers who revealed high discount rates based on the pairwise comparisons to indicate higher discount rates using the open-ended question.

Among the borrowers with debt who participated in the first wave of interviews, there is a strong positive correlation between the amount owed and the discount factor using either of our measures. We cannot, of course, determine whether the need for money to pay off debts induces the high discount rate or whether individuals with high discount rates tend to owe more money. The eighty borrowers claiming no debt do not have particularly low discount rates perhaps because they anticipate a high likelihood of future adverse shocks. The average amount they say they would need in a month to forego S\$500 immediately is only modestly below the sample average.

⁶There are three respondents with inconsistent answers.

Finally we asked respondents to choose between getting S\$320 in nine months and S\$356, S\$392, and S\$427 in ten months. These numbers are designed to elicit answers similar to those involving the option of \$180 immediately if our respondents are geometric discounters. Note that they could depart from geometric discounting if they are hyperbolic discounters but also if they expect to be less liquidity-constrained in nine months. Regardless of the reason, borrowers discount at a lower rate in the future. Fully 22 percent would accept the lower figure and 59 percent the middle figure while only 13 percent would reject the highest.⁷ Consistent with this when asked how much they would require in ten months to forego S\$800 in nine months, on average they require only S\$1001.

3.5 Lenders

We have relatively little information about the lenders. For each lender, we collected the name by which they were known to the borrower, the borrower's assessment of the lender's age in broad categories and whether they thought the lender's business was small, modest, big, or very big. Our enumerators recorded a very large number of distinct names. We corrected obvious spelling errors and likely differences in transliterations of Chinese names and assumed that Ah (Chinese for Mr.) Lee and Mr. Lee were the same name but kept Bill and Ah Bill as distinct names. We made the same judgment for names like James, Jimmy and Big Jim. This left us with 724 distinct names of which 327 were mentioned by only a single borrower. Still, we have 304 lenders from whom at least three borrowers report obtaining a loan.

We take these numbers with a large grain of salt. Doubtless, some lenders are known to different borrowers by distinct albeit similar names, and there could easily be more than one lender with a given name operating in different locations. However, when we look at the most common name in our sample, no clear pattern suggesting multiple lenders emerges.

Nevertheless, to guard against the possibility that two borrowers transacted with different lenders with the same name, we present results in which we control for the lender name/borrower pair. We would only confound lenders in this case if a borrower obtained loans from two different lenders using the same name, which we view as highly improbable.

4 The Loans

We begin by summarizing the loan data for the entire period although changes over time will be an important part of our later discussion.

⁷Six respondents had inconsistent responses.

The loans requested ranged from S\$100 to S\$50,000 and averaged S\$1,776. The actual loans granted average S\$1,453. Thus, consistent with Ghosh and Ray (2016), with a high rate of default we observe micro-rationing under which lenders do not agree to the full loan requested by the borrower. Also consistent with their model, we find some evidence that rationing declines with the number of interactions between the lender and borrower although the effect is modest. Both the loans asked and the loans granted increase with the number of prior contacts, but the former increases more rapidly.

The agreed upon rate for six weeks averaged 22 percent although, as we have already noted, since repayments are typically made in six equal installments, the actual rate is much higher. We cannot calculate the actual interest rate paid on any given loan since we do not know the timing of payments. For each loan we can calculate the minimum rate for six weeks under the assumption that all payments were made at the end of the loan. This averages 35 percent or about 5.2 percent per week for loans that were eventually repaid in full.

If we assume that all borrowers who repaid their loans in-full did so in equal half month installments, the average loan and the average discounted flow of payments are equalized at an interest rate of 5.6 percent per week. While these calculations must be treated with considerable caution, there does not appear to be a large interest rate penalty for failure to repay on time.

Only 14 percent of loans were repaid in-full and on-time. 92 percent were eventually repaid with an average repayment period of almost fifteen weeks. Loans were unsecured although lenders did collect ‘collateral’ that enhanced their ability to collect repayment. Almost all transactions required the borrower’s ID and 71 percent required additional ID from a friend. In one-sixth of transactions, the borrower handed over his Singapore Pass. The SingPass is a unique online identity that the government assigns to every citizen in Singapore.⁸

One way to repay the loan is to work for the loanshark. When borrowers report repaying the loan in-full, they report working for him less than five percent of the time, mostly by laundering money but also by helping to disburse or collect loans. However, when borrowers report only partially repaying the loan, they ended up working for the loanshark nearly half the time.

Borrowers provided up to eight reasons that they chose a particular lender for the transaction. The most common (56 percent) was that he was referred by a friend or regular customer, followed by the lender’s willingness to lend the amount requested (46 percent).

⁸It can be used to access virtually all the information that the government has collected about that specific citizen. This information includes the individual’s job history, medical records and housing payments. Citizens can also use SingPass to apply for online visas for friends visiting Singapore.

Borrowers also preferred the possibility of a longer tenor and the option of payment in installments (26 percent), lenders with whom they had a history (24 percent), and who were easy on collateral (19 percent). The interest rate and less physical violence were mentioned in the case of only 11 and 8 percent of transactions. On average, borrowers said they transacted with the same lender twice a year and that this was the fifth overall transaction with the same lender.

Borrowers reported up to three ‘conditions’ when they took the loan. Six different conditions were reported: normal, after drinking, under the influence of drugs, while gambling, under threat, and under the influence of a woman. While borrowers report taking out 40 percent of the loans “under normal conditions,” many of these actually report conditions that we would not view as normal. Almost half of the loans occurred under the influence of gambling; one-third occurred after the borrower had been drinking. One in seven report having faced threats. For only about one-sixth of loans do borrowers not report the influence of any of drinking, drugs, gambling or threats.

The borrowers’ reasons for taking out a loan are similar to the conditions under which they took out the loan. Over half (55 percent) said they needed the loan to gamble and one-eighth (13 percent) needed it to pay a gambling debt. One-third (34 percent) needed the money to pay off a debt while 14 percent planned to use it to treat friends and 13 percent for the entertainment of a woman or the services of a sex worker. While some of the reasons, such as medical care for a child, would generally be viewed as emergencies beyond the borrower’s control, relatively few cited such reasons.

When the borrower paid in-full and on-time, there was relatively little enforcement activity from the lender. For 92 percent of such transactions, no harassment is reported. The remaining eight percent only report reminders or threats. More serious harassment is reported for only about 0.5 percent of the loans that were reportedly repaid in-full and on-time.

In contrast, when the borrower failed to pay in-full and on-time, harassment almost always ensued. Only seven percent of such transactions were not accompanied by some act of harassment. The most common was a reminder or harassing phone call, letter or verbal threat. Such acts are reported in 90 percent of cases. 22 percent involve what we term potential loss of face,⁹ 15 percent vandalism, 7 percent actual loss of face¹⁰ and 2 percent the threatened or actual use of the Singapore Pass for illicit purposes.

Borrowers found a variety of means to repay the lender. Most (86 percent) used their

⁹Knocking on doors or gate or visiting the borrower’s workplace

¹⁰Shouting at the borrower in his neighborhood or a public venue, harassing him at his workplace or harassing family, friend or neighbors.

income or a rental deposit, at least in part, but almost half (47 percent) borrowed from another lender, and a similar proportion (54 percent) borrowed from friends and/or relatives. 14 percent used gambling winnings and 13 percent either sold or pawned items.

5 Model

The model we develop in this section is simple but designed to capture key elements of the unlicensed moneylending market described earlier: 1) lenders and borrowers must rely exclusively on relational contracts to enforce loan transactions, 2) there is considerable information asymmetry between the parties regarding the borrowers' ability to make repayments on time, 3) borrowers frequently fail to repay on time, but 4) almost all eventually repay in full, and 5) harassment of borrowers by lenders is pervasive, but harassment is rare when the loan is repaid in full and on time. In our model, 1) and 2) are true by assumption. Elements 3-5 arise as the outcomes of a relational contract. We then apply the model to predict the likely effects of increased police activity aimed at reducing illegal moneylending.

5.1 Setting

We model the relation between a single borrower and lender, ignoring the possibility that borrowers may have relationships with more than one lender. Formally, a borrower (B or she) and a lender (L or he) interact repeatedly in a borrowing relationship. We normalize the loan size to be one unit. Time is discrete and denoted by $t = 0, 1, \dots, \infty$. Both parties are risk-neutral and share the same discount factor $\delta \in (0, 1)$.

Each period t moves as an extensive-form game. Play proceeds as follows.

At the beginning of period t , the borrower approaches the lender and asks for a loan. The lender decides to offer a loan to the borrower which requires a repayment amount x_t (denoted as $O(x_t)$) or not (NO). If a loan is offered, the borrower then decides to accept (A) it or not (NA). Let these actions be defined as $o_t \in \{O(x_t), NO\}$ and $a_t \in \{A, NA\}$, respectively.¹¹ In the case that either $o_t = NO$ or $a_t = NA$, each party receives an outside option value 0, and time moves on to period $t + 1$. Alternatively, if $o_t = O(x_t)$ and $a_t = A$, the loan generates a value u to the borrower and has a cost, which we normalize to be 0, to the lender.

After the loan is made, nature determines the state of the world, θ_t , to be large (l) or small (s). States are drawn independently across time, with states l and s occurring with

¹¹When the lender decides to offer a loan to the borrower, there is a continuum of actions he can choose from, which differ from each other in the amount of repayment he requests. For notational simplicity, we compress these actions into one expression, $O(x_t)$.

probabilities $q \in (0, 1)$ and $1 - q$ in each period. The borrower observes the realized state θ_t , while the lender only knows the distribution of the states.

After state θ_t is realized, the borrower decides whether to delay (D) the repayment or to make it on time (ND). We abstract from the possibility that she might make a partial payment or, admittedly implausibly, overpay. Denote this action as $d_t \in \{D, ND\}$. If $d_t = ND$, the borrower transfers x_t to the lender. If instead $d_t = D$, the borrower enjoys a benefit, ρ_{θ_t} , and does not make a transfer to the lender who therefore bears a cost, c_D . We call ρ the value of late repayment, where $0 < \rho_s < \rho_l$.

Seeing the borrower's action d_t , the lender decides whether to harass (H) or not to harass (NH) the borrower. Let $h_t \in \{H, NH\}$ denote this action. If $h_t = H$, the lender and the borrower incur costs c_L and c_B , respectively. Alternatively, if $h_t = NH$, there is no cost to either party.

Lastly, the borrower decides whether to repay (R) the amount x_t or not (NR). For simplicity, we will assume that the the second repayment amount to x_t . Denote this action as $r_t \in \{R, NR\}$. Note that playing NR after D corresponds to defaulting on the loan.

After this, time moves on to period $t + 1$. The game tree in period t is described in Figure 1.

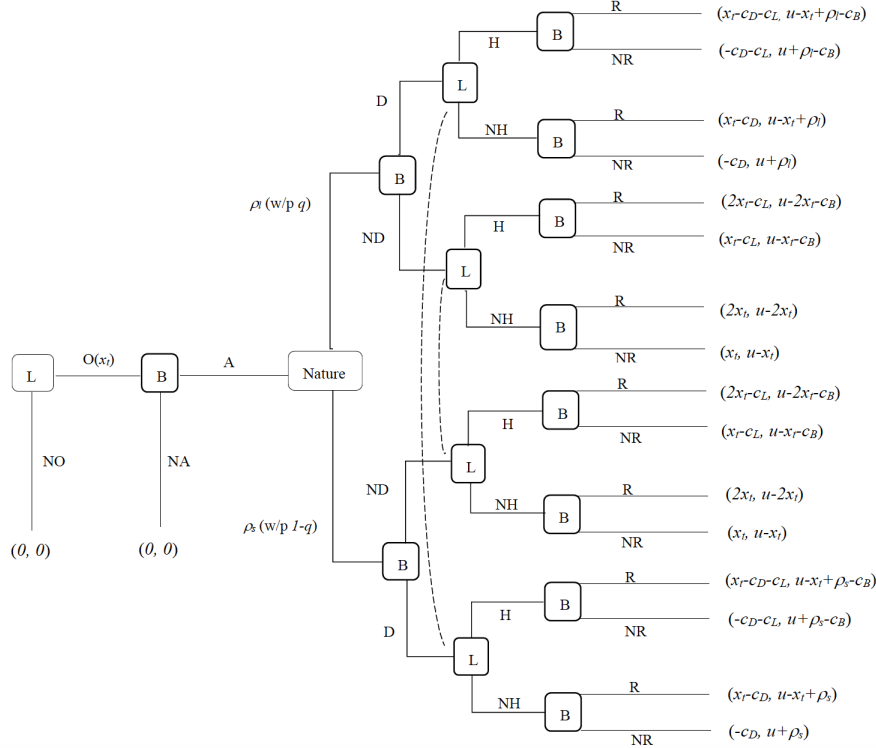

Figure 1: Game Tree in Period t

At the beginning of any period t , the lender and the borrower's life-time expected payoffs, $\pi_{L,t}$ and $\pi_{B,t}$, are given by

$$\pi_{L,t} = \sum_{\tau=t}^{\infty} \delta^{\tau-t} \mathbf{E} \{ 1_{\{o_\tau=O(x_\tau)\}} 1_{\{a_\tau=A\}} [(1 - 1_{\{d_\tau=D\}}) x_\tau - 1_{\{d_\tau=D\}} c_D - 1_{\{h_\tau=H\}} c_L + 1_{\{r_\tau=R\}} x_\tau] \},$$

$$\pi_{B,t} = \sum_{\tau=t}^{\infty} \delta^{\tau-t} \mathbf{E} \{ 1_{\{o_\tau=O(x_\tau)\}} 1_{\{a_\tau=A\}} [u - (1 - 1_{\{d_\tau=D\}}) x_\tau + 1_{\{d_\tau=D\}} \rho \theta_\tau - 1_{\{h_\tau=H\}} c_B - 1_{\{r_\tau=R\}} x_\tau] \}.$$

In which, $1_{\{o_\tau=O(x_\tau)\}}$ is an index function that equals 1 if $o_\tau = O(x_\tau)$, and equals 0 if $o_\tau = NO$. The other index functions, $1_{\{a_\tau=A\}}$, $1_{\{d_\tau=D\}}$, $1_{\{h_\tau=H\}}$, and $1_{\{r_\tau=R\}}$ can be interpreted similarly.

The equilibrium concept used here is Perfect Bayesian Equilibrium (hereafter equilibrium for short). Formally, denote $\phi_t = \{o_\tau, a_\tau, d_\tau, h_\tau, r_\tau\}_{\tau=0}^{t-1}$ as the public history at the beginning of period t , and $\tilde{\phi}_t = \phi_t \cup \{\theta_\tau\}_{\tau=0}^{t-1}$ as the private history to the borrower at the beginning of period t . Denote Φ_t as the set of public histories and $\tilde{\Phi}_t$ as the set of private histories to the borrower. As usual, we let $\Phi_0 = \tilde{\Phi}_0 = \emptyset$. A behavioral strategy for the lender, denoted as $\sigma_L = \{\sigma_{L,t}^o, \sigma_{L,t}^h\}_{t=0}^{\infty}$, is a sequence of functions determining the probabilities with which the lender plays his actions following every public history; that is, $\sigma_{L,t}^o : \Phi_t \rightarrow \Delta\{O(x_t), NO\}$ and $\sigma_{L,t}^h : \Phi_t \cup \{o_t, a_t, d_t\} \rightarrow \Delta\{H, NH\}$. Similarly, a behavioral strategy for the borrower, denoted as $\sigma_B = \{\sigma_{B,t}^a, \sigma_{B,t}^d, \sigma_{B,t}^r\}_{t=0}^{\infty}$, is a sequence of functions determining the probabilities with which the borrower plays her actions following every private history; that is, $\sigma_{B,t}^a : \tilde{\Phi}_t \rightarrow \Delta\{A, NA\}$, $\sigma_{B,t}^d : \tilde{\Phi}_t \cup \{o_t, a_t, \theta_t\} \rightarrow \Delta\{D, ND\}$ and $\sigma_{B,t}^r : \tilde{\Phi}_t \cup \{o_t, a_t, \theta_t, d_t, h_t\} \rightarrow \Delta\{R, NR\}$. We also allow the parties to condition their actions on public randomization devices.

In our setting, the lender forms beliefs about the states of the world, or equivalently the values of late repayment to the borrower, in each period. A belief system for the lender, denoted as $\mu = \{\mu_t\}_{t=0}^{\infty}$, is a sequence of functions that the lender assigns probabilities to the values of late repayment after every public history $\phi_t \cup \{o_t, a_t, d_t\}$; that is, $\mu_t : \Phi_t \cup \{o_t, a_t, d_t\} \rightarrow \Delta\{\rho_s, \rho_l\}$.

A strategy profile (σ_L, σ_B) and a belief system μ consist of a Perfect Bayesian Equilibrium if (i) given the belief system and the other party's strategy, each party's strategy maximizes his/her payoff after every history, and (ii) the belief system μ is updated using Bayes' rule whenever possible.

We define a relational contract as an equilibrium of the game.¹² For our interest, we focus on stationary equilibria, in which the parties' strategies are history-invariant on equilibrium

¹²In the unlicensed moneylending market, it is unlikely that someone has long-term commitment power that governs his/her moves according to decisions made at the beginning of the relationship. Therefore we do not build the model as the lender or the borrower's optimal dynamic contracting problem.

paths.

We make some assumptions as follows.

Assumption 1 $u > c_D + c_L + c_B$.

This is a sufficient, but far stronger than necessary, condition which ensures that a loan has positive net surplus for the parties to share even if the borrower always delays the repayment and the lender always harasses the borrower.

Assumption 2 $\rho_l > c_D + c_L + c_B$ and $\min\{c_D, c_B\} > \rho_s$.

These inequalities mainly ensure that it is socially efficient for the borrower to delay the repayment if and only if the value of late repayment is large.

Assumption 3 $(1 - q)(c_D - \rho_s) > q(c_L + c_B)$.

This assumption says that the cost of enforcing on-time repayment is less than the social gain from the enforcement when the value of late repayment is small.

Finally, we will provide a short discussion about some of our modelling assumptions. One of the aspects we build in the model is that we let the borrower enjoy a benefit ρ when she delays repayment. The interpretation for this could be that if a borrower borrows to gamble and loses, she may have to liquidate her possessions or borrow from other sources to repay the loan. Delaying repayment and hence having more time to raise funding may help the borrower reduce the cost of funding, which turns out to be a benefit to her. A large (ρ_l) or small (ρ_s) value of late repayment then is related to the level of liquidation of possessions or new borrowing. Importantly, this level is unlikely to be known to the lender. As a result, information asymmetry arises.

Another aspect in the model is that we let the value u of a loan for the borrower be fixed, so it is independent of the repayment amount x_t or the value ρ of late repayment. As seen from the data, the majority of borrowers spend their loans on gambling/drinking, lavish affairs or repaying outstanding debts. These activities often occur just after the loans are received. Therefore, the value of a loan is more likely determined by how it is spent, and is less affected by how it will be repaid in future. We acknowledge that u may depend on the loan size in reality. However, since we normalize the loan size to be one unit, this effect is absent in the current model.

The third aspect is that in the model we endogenize the repayment amount x_t but fix the loan size. An alternative way to write the model is to let the loan size vary but to fix the repayment amount. This method of modeling is also relevant to the market, as lenders

typically have a sense of a borrower's ability or willingness to repay a loan. They therefore restrict their request for loan repayments to an affordable level for the borrower, and adjust the loan sizes accordingly. We expect these modeling methods to generate qualitative results similar to each other.

5.2 Analysis of Equilibrium

We are only interested in efficient, stationary equilibria. Within this set, we will focus on a particular equilibrium with two nice properties. First, it fits what we observe in reality. Second, if we imagine pre-game bargaining according to Nash bargaining, then this is what would be selected.

We begin by showing the existence of a stationary equilibria with the following properties in proposition 1: in each period, a) the lender offers a loan requiring a repayment x and the borrower accepts the loan, b) the borrower delays the repayment if and only if the value of late repayment is large, c) the lender harasses the borrower with probability p when the borrower delays the repayment, and does not harass her otherwise, d) the borrower finally repays x if and only if she has delayed it. Moreover, e) the parties' payoffs are proportional to the total surplus generated in the equilibrium. Let the borrower and the lender's shares of surplus be labeled as $\lambda \in (0, 1)$ and $1 - \lambda$, respectively.

Proposition 1 *Under assumptions 1-3 and for $\delta \geq \bar{\delta}$, where $\bar{\delta}$ is a cutoff value derived in the appendix, there exists an efficient stationary equilibrium of the game which has the characteristics a-e with values p and x given by equations (1) and (2). This equilibrium has comparative statics such that $dx/dc_L > 0$, $dp/dc_L = 0$ and $dx/d\lambda < 0$.*

Proof. See Appendix. ■

Given the existence of equilibrium $C(x, p)$, the total surplus π , the lender's payoff π_L and the borrower's payoff π_B are given by

$$\pi = \frac{1}{1-\delta}(u + q(\rho_l - c_D) - qp(c_L + c_B)), \quad \pi_L = \frac{1}{1-\delta}(x - q(c_D + pc_L)) \quad \text{and}$$

$$\pi_B = \frac{1}{1-\delta}(u - x + q(\rho_l - pc_B)),$$

respectively. Effectively, in equilibrium $C(x, p)$, p determines the total surplus and x determines the allocation of surplus between the parties.

We pin down the values of x and p in equilibrium $C(x, p)$ with expressions

$$p = \frac{\rho_s}{c_B}, \tag{1}$$

which we show in the proof is the lowest probability of harassment that supports the existence of a stationary equilibrium with characteristics a-d, and

$$x = (1 - \lambda)(u + q(\rho_l - \rho_s)) + \lambda q(c_D + \frac{\rho_s c_L}{c_B}), \quad (2)$$

which divides the surplus according to the parties' shares.

Notice that under assumptions 1-3, equilibrium $C(x, p)$ is efficient, implying that it maximizes the total surplus among all possible stationary equilibria. In any stationary equilibrium of the game in which the borrower delays if and only if the value of late repayment is large, the lender should harass the borrower with probability no less than ρ_s/c_B when delay occurs. Hence, any such equilibrium has a larger deadweight loss caused by harassment compared to equilibrium $C(x, p)$. Alternatively, in any stationary equilibrium in which the borrower always delays, or never delays, or delays if and only if the value of late repayment is small, the total surplus generated by this equilibrium is bounded above by a value lower than the total surplus generated by equilibrium $C(x, p)$.

Although equilibrium $C(x, p)$ is efficient, it is not the only one. The construction of equilibrium $C(x, p)$ can be modified slightly to show that there is a set of efficient stationary equilibria all of which have characteristics a-d with the same probability of harassment ρ_s/c_B , but can differ in the loan repayments. Denote this set of equilibria as \mathbf{C} . Therefore, there is the issue of equilibrium selection. Potentially there are many ways to select equilibrium $C(x, p)$ from set \mathbf{C} . One possible way is to introduce pre-game bargaining according to Nash bargaining. In other words, before the game starts in period 0 the parties Nash bargain over which equilibrium in set \mathbf{C} is to be played, where λ and $1 - \lambda$ are the borrower and the lender's bargaining powers. This amounts to say that the parties determine the repayment amount x according to the problem

$$\max_{\{x\}} \left(\frac{u - x + q(\rho_l - \rho_s)}{1 - \delta} \right)^\lambda \left(\frac{x - q(c_D + c_L \rho_s / c_B)}{1 - \delta} \right)^{1 - \lambda},$$

which gives exactly the expression (2). Applying this refinement to our model, yields $C(x, p)$ as the unique, stationary and efficient equilibrium.

Corollary 2 *Equilibrium $C(x, p)$ will be uniquely selected by pre-game Nash bargaining from the set \mathbf{C} of most efficient equilibria.*

5.3 Discussion

Equilibrium $C(x, p)$ captures some key elements of what we observe in the market. Borrowers frequently fail to make repayments on time, but almost all eventually repay in full. Lenders often resort to harassment when borrowers are late in repaying loans, but rarely do so when repayments are made on time. Besides, although lenders are no doubt in an advantageous position in loan transactions, borrowers still manage to receive some benefits due to information asymmetry or their possible choice to run away. For this reason, equilibrium $C(x, p)$ enables us to conduct comparative statics and deliver policy implications.

We discuss some comparative statics based on equilibrium $C(x, p)$. Enforcement carried out by authorities to crack down on the unlicensed moneylending market is most likely to increase the lenders' cost c_L of harassment. Note that

$$\frac{dx}{dc_L} = \frac{\lambda q \rho_s}{c_B} > 0.$$

Intuitively, to offset the increase of the cost of harassment caused by enforcement, lenders request higher repayments for loans. Note that in the limiting case where $\lambda = 0$, the lender captures all surplus, the required repayment does not change. Thus if we find a government crackdown on lenders raises interest rates, it suggests, at least within the context of the model, that borrowers obtain some benefits from the transactions.

Strikingly, our model predicts no effect on harassment; that is,

$$\frac{dp}{dc_L} = 0.$$

Lenders are (partially) compensated for their increased costs through higher payments. Total surplus is reduced. Informally, if there is a distribution of expected profit lenders require to keep them in the market, some lenders may be driven from the market. This may, in turn, reduce the borrowers' share of surplus, λ . Because

$$\frac{dx}{d\lambda} = -(u + q(\rho_l - c_D - \rho_s(1 + \frac{c_L}{c_B})) < 0,$$

this further raises the required repayments for loans.

Since loan size, the value of late repayment and the probability of having a large value of late repayment are all exogenous in the model, by design, police enforcement cannot change them. Informally, we would expect the higher interest rate to reduce the size of loans requested but not sufficiently to maintain the likelihood that borrowers can repay on time. This would increase the frequency of harassment but is not conditional on whether or not

the loan is repaid on time. The conditional probability will change only if either the cost of harassment to the borrower or the value of late repayment when small changes. While the likelihood that police enforcement has no effect on these parameters is small, we see no obvious argument regarding the direction of the effect.

6 The Policy Setting

Prior to 2009, there was very limited information regarding unlicensed moneylending activities in official venues. From 2009 onwards, the Singaporean authorities passed legislation intended to clamp down on unlicensed moneylenders and to discourage borrowers from participating in this market (Singapore Police Force 2012, 2013; Kalyani 2012). However, the period before 2014 also coincided with a significant drop in the resources available to law enforcement that prevented it from implementing the laws. We provide a brief overview of the major policies.

In 2010, the “Moneylenders Act” was amended to increase the jail term and fines for unlicensed moneylending, and extended penalties to individuals assisting the lenders (Ministry of Finance Singapore, 2013). According to Singapore Police Force (2012), the National Crime Prevention Council (NCPC) set up a hotline allowing the public to report information anonymously. Starting in May 2012, CCTV cameras were installed in public housing buildings and nearby parking lots (Coconuts Singapore, 2016). At the end of 2012, the Singapore Police Force and NCPC launched a public education campaign about unlicensed moneylending (Kalyani, 2012).

At the same time, police resources were being stretched. The Singapore Police Force, the authority charged with enforcing the laws against unlicensed moneylending, had an “exceedingly low ratio” of police officers to population compared to cities such as Hong Kong, New York, and London (Hussain, 2014). The police commissioner reported that the force had fallen from 222 officers for every 100,000 residents in 1994 to 163 at the beginning of 2014, and maintained that “Geylang and Little India had already stretched police resources to near breaking point.” In response, the government increased police salaries and recruitment bonuses in order to significantly increase hires and retention (Seow, 2014).

Our interpretation, based in part on these data and qualitative interviews is that while there was no single sharp change in policy, the expansion of the police force in 2014 caused the most critical shift. Our qualitative interviews revealed that loansharks became much more concerned about police enforcement and began to exit the industry. From the data, this belief held by unlicensed moneylenders as described by the market insiders is reinforced by the sharp change in the proportion of loans that were obtained from a lender with whom

the borrower had not previously contracted. From 2009 through 2012, this proportion hovered around 10 percent before jumping to 17 percent in 2013 and 38 percent in 2014. Similarly, when asked why they chose this particular lender, from 2009 through 2013, fewer than one percent of transactions elicited the response that the borrower had few or no other lender contacts. This jumps to twenty percent in 2014 before falling again. Further, while an average of 16 percent of such transactions in the earlier period elicited the response “history with the lender,” this jumps to 73 percent in 2015.

Finally, the enumerators were told to report any major events that affected the behavior of borrowers or lenders in the unlicensed moneylending market. In 2014, all the enumerators reported that the number of lenders they knew who were still operating in the market had fallen significantly. The enumerators attributed this to enforcement activities carried out by the authorities. Throughout the years, they did not report any other significant events.

7 Effects of the Policy Change

7.1 Methods

Our approach is simple. We begin by regressing the dependent variable (e.g. the nominal interest rate) on the controls and a set of year dummies. We then regress the coefficients of the year dummies, including 0 for the excluded year, on a constant term for the period following increased enforcement. Under the assumption that the first-stage coefficients are i.i.d. normal except for a shift in the mean due to enforcement, the t -statistic on the resulting estimate is distributed as t with five degrees of freedom (Donald and Lang, 2007). Note that the .05 critical value is 2.57. Alternatively, following Hagemann (2019), we can perform randomization inference on the eight coefficients. Since there are 56 ways to choose three years out of eight, significance at the .05 level using this method effectively amounts to the three enforcement years having either the three largest or three smallest coefficients. We test for significance using the latter approach, but present standard errors using the former since they provide the reader with a sense of the precision of our results. Fortunately, there are only a few estimates for which we find statistical significance using one approach but not the other.

Of course, the post-enforcement period could differ from the earlier period simply because of a continuing trend. To address this, we visually inspected the coefficients from the first stage for signs of a trend. When there were signs of a trend, we then asked whether the inclusion of a trend in the second stage substantially alters the interpretation of the results by making a significant coefficient negligible or reversing the sign. There are a few instances

where we alert the reader to possible concerns.

For each dependent variable, we present four specifications. In the first we compare the pre- and post-enforcement periods with no further controls. This captures all changes whether they are due to who borrows, who lends or what happens within borrower-lender pairs. This serves as a baseline but is unlikely to be of policy interest.

Second, we include borrower fixed effects. This is likely to be of greatest interest to policy makers. Since all of our borrowers remained active in the market after enforcement increased, it essentially measures the change in their experience and is likely to be reflective of the effect on regular borrowers. As noted earlier, we almost definitely miss some very occasional borrowers. We will not capture any impact on their presence in the market.

Third, we include lender, but not borrower, fixed effects. This tells us the extent to which any policy effects are driven by altering which lenders remain in the market.

Finally, we include borrower-lender pair fixed effects. Since our theoretical model is formally about what happens within such a pair, these results probably come closest to addressing the predictions of our model.

7.2 Results

Table 3 presents the results. The first line shows the effect of enforcement on the nominal interest rate quoted to the borrower. Consistent with the theoretical model, regardless of the specification, the interest rate is estimated to have risen by about fifteen basis points. These estimates are statistically significant at the .05 level. In all four first-stage estimates (not shown), there is a sharp jump in 2014 followed by smaller increases in each of the next two years.

Although our model does not address the size of the loan, informally, we would expect enforcement to reduce the amount borrowers are able to obtain from lenders. There is less benefit from delaying payment on a small loan and therefore less need to deter the borrower from falsely claiming she cannot repay. This becomes more attractive as the cost of enforcement increases. The second line of the table shows that the size of loans decreased by between S\$1000 and S\$1200 depending on the specification. Again, these estimates are all significant at the .05 level.

In the third line, we see a similar albeit somewhat smaller decline in the amount borrowers requested. This could reflect either the higher cost of loans or might reflect borrowers' expectations regarding the size of the loans lenders were willing to offer. Nevertheless, the point estimates suggest that increased enforcement further increased the rationing of the loans by about 27 percent OR S\$200 (see fourth line). The difference between the coefficients

is significant at the .05 level in all but the specification with borrower fixed effects. However, there are also signs of pre-trends in some specifications, leaving us reluctant to reach any strong conclusions.

Did the combination of higher interest and smaller loans raise or lower total payments? This is addressed in the fifth line of the table. The point estimate suggests that total payments declined albeit not by as much as the decline in the amount borrowed. Only the estimates using borrower or borrower-lender fixed effects are statistically significant using Hagemann although all four are if we use Donald-Lang. Moreover, when we include borrower-lender fixed effects, there is evidence of a pre-existing trend. Allowing for a trend makes the coefficient on enforcement small and highly insignificant, but the resulting confidence interval includes large effects. We conclude that the weight of the evidence is that there is some reduction in the amount borrowers pay, but cannot completely rule out the absence of any effect.

Despite the smaller loans, potentially reduced total payments, higher interest rate and potentially greater difficulty of finding another lender to help pay back the loan, the probability that a loan was not paid back in-full and on-time jumped by a statistically significant 15 to 18 percent depending on the specification (see sixth line).

We coded twenty-nine ways of repaying the lender, and we have four different specifications for each method; therefore, we do not present the results in the table. In order to avoid spurious findings, we limit ourselves to reporting methods for which we do not detect evidence of a pre-trend and for which the effect is significant in all four specifications. The only repayment method that met this criterion was borrowing from family and relatives which increased by 14 or 15 percent depending on the specification. We also see weaker evidence of increased borrowing from friends and acquaintances, including work colleagues. The estimated increase ranges from 10 to 14 percent depending on the specification, but falls short of statistical significance when borrower-lender fixed effects are included in the specification.

In light of the higher default rate, it is perhaps not surprising that lenders were about six percentage points more likely to engage in some form of reminder/harassment activity if the borrower did not pay in-full and on-time (see line with “No Harassment”). This estimate is statistically significant at the .05 level in all specifications albeit only using Donald-Lang when borrower-lender fixed effects are included.

The only clear evidence we have of an increase in such activities is for ‘reminder’ phone calls and letters. These increased by about eight percentage points (significant in all specifications). However, the point estimates for activities involving potential loss of face by the borrower are large in all specification but much too imprecise for us to draw any conclusions.

While an increase in harassment activities involving potential loss of face is not consistent with our formal model, the absence of any evidence for increases in more significant forms of harassment is consistent with that model.

8 Discussion and Conclusion

The popular image of loansharks involves violent criminal bosses inflicting significant bodily harm on their unfortunate victims. While we do not wish to suggest that severe punishments are unheard of, and we recognize that our sample may not be fully representative, our data tell a different and more complex story. The borrower-lender relationship is heavily supported by the mechanism behind relational contracts: both parties wish to continue contracting. At the same time, the lenders' capacity to inflict harm in ways other than simply by leaving the relationship, facilitates the existence of such contracts. Importantly, borrowers who pay in-full and on-time are rarely subjected to significant harassment. Even borrowers default on the loan are largely punished by continuing to accrue interest at a very high rate.

Moreover, our results suggests that borrowers are not powerless in the relationship. Our theoretical model implies that a police crackdown on harassment activities, in particular, and illegal moneylending, in general, raises the interest rate in the market only if borrowers have some bargaining power. An increase in the nominal interest rate from 20 percent over six weeks to 35 percent suggests to us both that borrowers have some power in the relationship and that the crackdown was effective in raising the cost to lenders even though it did not reduce harassment.

Our model has no externalities. Although there is asymmetric information, making it possible at least in theory, to improve upon the contracts, both parties enter freely into the contract. At least, those in our sample participate sufficiently frequently in the market that it is difficult to argue that borrowers do not anticipate what will happen if they default or the likelihood that they will default. From a neo-utilitarian perspective, outlawing and clamping down on loansharks cannot be desirable in such a model. Consistent with this, Singapore's crackdown successfully reduced the availability of loansharks, and raised the interest rate and may not even have reduced the size of loan repayments even though it reduced the size of loans.

On the other hand, outside a neo-utilitarian perspective, it can be argued that many of our borrowers need to be protected against themselves. They incur gambling losses that they can repay only with great difficulty. They often borrow under the influence of alcohol, drugs or in the heat of the moment. They have extraordinarily high discount rates even when they are not in debt. Further, they prefer to spend their money on entertaining their

friends lavishly.

Moreover, it is clear that such behaviors impose an externality on friends and family with the resources to help the borrowers. Of course, friends and family could choose not to help with debt repayment, but to some extent the loss of face the lender can impose on the borrower rebounds on family and close friends. Or, these family and friends may simply be unwilling to let the borrower suffer the consequences of further delay in repayment. Moreover, it is possible that, were such transfers possible, friends and family would be willing to compensate loansharks not to lend. Unfortunately, our survey was not designed to tell us how the Singapore crackdown affected borrowing from friends and relatives. *A priori* we can imagine an effect in either direction. However, we note that after the crackdown, at least when repaying the loanshark, borrowers became more likely to borrow from family and friends. Unfortunately, since we do not know the change in the number of loans, we cannot tell whether the net effect was increased or reduced borrowing from friends and relatives.

References

- Carina (2018). ‘Know the differences: Legal money lenders and loan sharks’, *Credit Hub Capital*, <https://credithubcap.com.sg/know-the-differences-legal-money-lenders-and-loan-sharks/>.
- CEIC (2019). ‘Singapore Gross Savings Rate’, <https://www.ceicdata.com/en/indicator/singapore/gross-savings-rate>.
- Chaia, A., Goland, T. and Schiff, R. (2010). ‘Counting the world’s unbanked’, *McKinsey Quarterly*, <http://www.mckinsey.com/industries/financial-services/our-insights/counting-the-worlds-unbanked>.
- Coconuts Singapore (2016). ‘Big brother is watching: Police to install CCTV cameras in every HDB block by year-end’, website, <http://singapore.coconuts.co/2016/03/09/big-brother-watching-police-install-cctv-cameras-every-hdb-block-year-end>.
- Donald, S.G. and Lang, K. (2007). ‘Inference with difference-in-differences and other panel data’, *The Review of Economics and Statistics*, vol. 89(2), pp. 221–233.
- Ghosh, P. and Ray, D. (2016). ‘Information and enforcement in informal credit markets’, *Economica*, vol. 83(329), pp. 59–90.

- Hagemann, A. (2019). 'Placebo inference on treatment effects when the number of clusters is small', *Journal of Econometrics*.
- Ho, O. (2016). 'From despair to desire to help others in debt', *The Straits Times*, <http://www.straitstimes.com/singapore/from-despair-to-desire-to-help-others-in-debt>.
- Hussain, A. (2014). 'More officers needed to better patrol hot spots: Police chief', <https://www.todayonline.com/singapore/more-officers-needed-better-patrol-hot-spots-police-chief>.
- Kalyani, K. (2012). 'Unlicensed moneylending is a criminal activity?: DPM Teo Chee Hean', https://www.hometeam.sg/m/article.aspx?news_sid=20121217wz8LWLwni7ad#.
- Kok, D. (2001). 'Stock market plunges with jailing of Ah Long San', <http://www.talkingcock.com/html/article.php?sid=668>.
- Meikle, J. (2014). 'Sixty victims of loan sharks in witness protection', *The Guardian*, <https://www.theguardian.com/uk-news/2014/jan/24/sixty-victims-loan-shark-witness-protection-illegal-moneylending>.
- Ministry of Finance Singapore (2013). 'Singapore national money laundering and terrorist financing risk assessment report. Singapore', , <http://www.mof.gov.sg/portals/0/data/cmsresource/Press%20Release/2013/Singapore%20NRA%20Report.pdf>.
- Ministry of Manpower (2016). 'Summary table: Income', <http://stats.mom.gov.sg/Pages/Income-Summary-Table.aspx>.
- Prabha, A.P. and Ratnatunga, M. (2014). 'Underground lending:submerging emerging asia?', .
- Seow, J. (2014). 'Measures to recruit more police', <https://www.asiaone.com/singapore/measures-recruit-more-police>.
- Singapore Police Force (2012). 'Annual Crime Brief', <https://www.police.gov.sg/~media/crimebrief2012.pdf>.
- Singapore Police Force (2013). 'Annual Crime Brief', <http://www.police.gov.sg/~media/crimebrief2013.pdf>.
- Singstat (2011). 'Census of population 2010 statisticl release 1', .

Table 1: Borrower's Characteristics

<i>Panel A: Basic Demographics</i>				
	Chinese	Malay	Indian	Other
Ethnicity	74.5	14.1	11.1	0.3
Education	Primary& Below	Junior School	Polytechnic	JC ¹ & Above
	22.9	36.6	34.1	6.4
<i>Panel B: Borrowing & Spending Behavior</i>				
	Never	Occasionally	Regular	Very Frequently
Borrow From FamilyFriends	2.48	31.28	38.07	28.17
Fail to Repay FamFriend	7.16	33.30	48.53	11.01
Borrow From Loanshark	1.28	41.65	41.65	15.23
Fail to Repay Loanshark	0.55	29.17	54.86	15.41
Drinking	3.58	16.61	40.37	39.27
Drug Abuse	69.63	12.39	10.28	7.71
Gambling	9.72	27.61	28.90	33.76
	Less than 10%	10%-20%	20%-40%	More than 40%
Saving	63.76	29.82	5.78	0.55
Lavish Spending	0.46	3.21	39.17	57.16

¹ JC refers to junior college. Polytechnic includes diploma or certificate.

² Every row in this table sums up to 100%.

Table 2: Loan Characteristics

<i>Panel A: Summary Statistics</i>			
Variable	Mean	Std. Dev.	N
Loan Asked ¹	1775.88	1614.56	10821
Loan	1452.92	1552.11	11018
Total Amount Paid	2456.55	2045.13	11032
Nominal Rate	0.22	0.07	11032
Repay Month	3.4	1.82	10570
Repay in-full on time	0.14	0.35	11031
Finally Repay ²	0.92	0.26	11031

<i>Panel B: When Borrow</i>			
Borrow Condition	Col%	Collateral	Col%
Under gambling	50.56	Personal ID	98.95
Under normal conditions	40.56	Friends ID	70.16
After drinking	34.13	Singpass	16.34
Under threat	14.02	Friends Phone	3.84
Under drug	8.86	Other	4.17

Why this Lender	Col%	Why Borrow	Col%
Referred by a trusted friend	56.86	Gambling	55.85
Willing to loan the amount	46.76	Buy drinks/drugs	48.21
Longer term /allow installment	26.75	Pay debt	34.38
Borrow history	24.16	Pay bills	20.81
He is easy on collateral	19.20	Treat friends	14.71
He offers the best rate	11.11	Entertainment/women	13.30

<i>Panel C: When Repay</i>			
How to Repay	Col%	Harassment	Col%
Using income	85.45	Phone call	50.47
Borrow from another lender	46.82	Verbal threat	43.23
Borrow from company/friends	27.38	Demand letter	26.71
Borrow from family and relatives	26.84	Nothing	19.75
Gambling winnings	14.35	Humiliation ³	22
Sell/Pawn Valuable	13.77	Vandalism	15

¹ Loan Asked is the loan amount the borrower asked to borrow. Loan refers to the actual amount the lender lent.

² Finally Repay refers to whether the borrower eventually paid off the entire loan (principle and all interest).

³ Humiliation in Panel C involves knocking on doors or gate or visiting the borrower's workplace.

⁴ Panel B and C present the most frequent chosen answers.

Table 3: **Effect of Enforcement**

Dependent Var	Baseline (1)	FE (Borrower) (2)	FE (Lender) (3)	FE (Borr-Lender) (4)
Nominal Rate	0.148 [†] (0.018)	0.151 [†] (0.016)	0.148 [†] (0.018)	0.145 [†] (0.015)
Loan	-1080.557 [†] (133.236)	-1151.541 [†] (93.512)	-1025.256 [†] (121.401)	-1174.777 [†] (218.689)
Loan Asked	-903.109 [†] (142.723)	-1018.604 [†] (128.643)	-850.648 [†] (114.372)	-926.151 [†] (197.812)
Ration on Loan Asked ¹	-174.967 [†] (41.872)	-164.227 (51.932)	-177.402 [†] (40.018)	-250.866 [†] (66.140)
Total Paid	-645.399 (235.086)	-743.640 [†] (173.633)	-596.097 (226.594)	-597.544 [†] (198.222)
Default ²	0.158 [†] (0.013)	0.151 [†] (0.030)	0.156 [†] (0.016)	0.176 [†] (0.045)
Repay by Borrow from Family	0.154 [†] (0.010)	0.142 [†] (0.031)	0.139 [†] (0.013)	0.138 [†] (0.017)
Repay Month	1.237 [†] (0.328)	1.148 (0.652)	1.154 [†] (0.299)	1.283 (0.426)
No Harassment	-0.061 [†] (0.006)	-0.058 [†] (0.012)	-0.060 [†] (0.008)	-0.063 [†] (0.024)
Reminder Call	0.085 [†] (0.006)	0.082 [†] (0.015)	0.080 [†] (0.008)	0.079 [†] (0.022)

Standard errors in parentheses

¹ Ration on loan asked is the difference between the loan asked and actual loan amount.

² Default refers to whether the borrower repaid in-full and on time.

³ Coefficients in the cell represents the enforcement effect on dependent variable from the second stage estimation.

⁴ † indicates the coefficient is significant at 0.05 using Hagemann's placebo test.

Appendix: Proof of Proposition

Proof of Proposition 1.

Since in the equilibrium $C(x, p)$ we construct the lender mixes between playing H and NH after the borrower plays D , we introduce a public randomization device as follows. After the borrower plays D , the public randomization device generates a message $m \in \{0, 1\}$ which is observed by both parties. Moreover, if $m = 1$, which occurs with probability p , the lender is recommended to play H ; while if $m = 0$, which occurs with probability $1 - p$, the lender is recommended to play NH .

We construct a strategy profile and a belief system as follows, in which values x and p are given by

$$x = (1 - \lambda)(u + q(\rho_l - \rho_s)) + \lambda q(c_D + \frac{\rho_s c_L}{c_B}) \quad \text{and} \quad p = \frac{\rho_s}{c_B}. \quad (\text{A1})$$

Strategy profile. Phase (I): In period 0 the play of the game starts with the following: a) the lender plays $O(x)$ and the borrower plays A , b) the borrower plays D if and only if $\rho = \rho_l$, c) the lender plays according to the recommendation generated by the public randomization device when the borrower plays D and NH otherwise, d) the borrower plays R if and only if she has played D . If no deviation from a-d is publicly observed, the play continues according to a-d; otherwise the play switches to Phase (II) starting from the next period. Moreover, if the lender deviates from a) by playing $O(x')$ with $x' \neq x$, the parties consequently play A , D , NH and NR in the current period; if the lender deviates from c), the borrower consequently plays NR in the current period.

Phase (II): The parties play NO , A , D , NH and NR in every period. After any observable deviation, the play stays in this phase.

Belief system. In Phase (I), the lender forms a belief that $\rho = \rho_l$ with probability one after seeing the borrower play D , and forms a belief that $\rho = \rho_s$ with probability one after seeing the borrower play ND . In Phase (II), the lender can form any belief about the values of late repayment.

We now consider the conditions for this strategy profile to support the existence of equilibrium $C(x, p)$. As standard in the literature, the play of NO , A , D , NH and NR in every period and the beliefs associated with it consist of an equilibrium. Therefore, after any observable deviation, each party's continuation payoff starting from the next period is 0. However, note that if the borrower deviates from b), which is privately observable to herself, in the next period the play still goes according to a-d.

If this equilibrium exists, the lender and the borrower's life-time expected payoffs at the

beginning of each period are

$$\pi_L = \frac{1}{1-\delta}(x - q(c_D + pc_L)) \quad \text{and} \quad \pi_B = \frac{1}{1-\delta}(u - x + q(\rho_l - pc_B)).$$

Publicly observable deviations. For the borrower to play R after she has played D , the non-deviation condition is

$$-x + \delta\pi_B \geq 0. \quad (\text{IC}_B\text{-R})$$

On the other side, for the borrower to play NR after she has played ND , the non-deviation condition is

$$\delta\pi_B \geq -x. \quad (\text{IC}_B\text{-NR})$$

If the borrower plays D , for the lender to follow the recommendation generated by the public randomization device, the non-deviation conditions are given by

$$-c_L + x + \delta\pi_L \geq 0 \quad (\text{IC}_L\text{-H})$$

when he is recommended to play H , and

$$x + \delta\pi_L \geq -c_L \quad (\text{IC}_L\text{-NH1})$$

when he is recommended to play NH . When condition $(\text{IC}_L\text{-H})$ holds, condition $(\text{IC}_L\text{-NH1})$ will hold.

If the borrower plays ND , for the lender to play NH , The non-deviation condition is

$$\delta\pi_L \geq -c_L. \quad (\text{IC}_L\text{-NH2})$$

For the borrower to play A when the lender plays $O(x)$, the non-deviation condition is

$$\pi_B \geq 0. \quad (\text{IC}_B\text{-A})$$

Lastly, the lender deviates from the equilibrium if he makes an offer other than $O(x)$, or if he makes no offer. The non-deviation condition in this case is

$$\pi_L \geq -c_D \quad \text{or} \quad \pi_L \geq 0. \quad (\text{IC}_L\text{-O})$$

Privately observable deviations. The borrower privately learns the value of late-repayment ρ in each period, and therefore she can take deviations observed only by herself. To ensure

that the borrower plays D if and only if $\rho = \rho_l$, the non-deviation conditions are given by

$$-x + \delta\pi_B \geq \rho_s - pc_B - x + \delta\pi_B \quad (\text{IC}_B\text{-ND})$$

in state s , and

$$\rho_l - pc_B - x + \delta\pi_B \geq -x + \delta\pi_B \quad (\text{IC}_B\text{-D})$$

in state l .

Under assumptions 1-3 and for values of p and x given in (A1), conditions (IC_B-NR), (IC_L-NH2), (IC_B-A), (IC_L-O), (IC_B-ND) and (IC_B-D) hold. Hence what is left to consider are conditions (IC_B-R) and (IC_L-H). Note that if $\delta \geq x/(u + q(\rho_l - p c_B))$, then condition (IC_B-R) is satisfied. For condition (IC_L-H), if $x \geq c_L$, it always holds; if $x < c_L$, it holds when $\delta \geq (c_L - x)/(c_L - q(c_D + p c_L))$.

Let

$$\delta_1 = \frac{(1 - \lambda)(u + q(\rho_l - \rho_s)) + \lambda q(c_D + \frac{\rho_s c_L}{c_B})}{u + q(\rho_l - \rho_s)}$$

and

$$\delta_2 = \left\{ \begin{array}{ll} 0 & \text{if } \frac{c_L}{(1-\lambda)(u+q(\rho_l-\rho_s))+\lambda q(c_D+\frac{\rho_s c_L}{c_B})} \leq 1 \\ \frac{c_L - (1-\lambda)(u+q(\rho_l-\rho_s)) - \lambda q(c_D + \frac{\rho_s c_L}{c_B})}{c_L - q(c_D + \frac{\rho_s c_L}{c_B})} & \text{if } \frac{c_L}{(1-\lambda)(u+q(\rho_l-\rho_s))+\lambda q(c_D+\frac{\rho_s c_L}{c_B})} > 1 \end{array} \right\}$$

Let $\bar{\delta} = \max\{\delta_1, \delta_2\}$. Then for $\delta \geq \bar{\delta}$, conditions (IC_B-R) and (IC_L-H) hold.

We shall also note that the belief system constructed above is updated according to Bayes' rule whenever possible. Therefore, the strategy profile and the belief system consist of an equilibrium.